

Specializing in Air Suspension for the Motorcycle Industry

BLEED FEED TECHNOLOGY

PLATINUM

AIR SUSPENSION

"It's all about the Ride"

H-D, V-TWIN, METRIC, STREET AND CUSTOM APPLICATIONS!



Baggers



Street



Softails

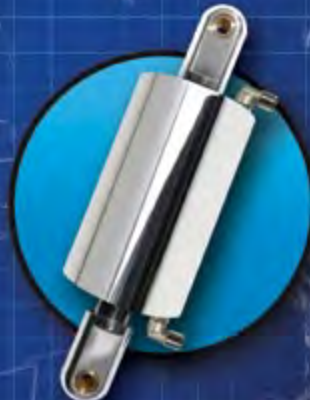

Indian

Bleed Feed & Simple Kits For All Models:

FLH'S & FLHT'S ROAD KING SPORTSTER / DYNA TWIN CAM
V-ROD SOFTAIL / EVO V-STAR INDIAN CHIEF HAYABUSA
YAMAHA R1 & R6 SUZUKI M109 GSX-R HONDA CBR
VICTORY STRYKER SABRE BOSS HOSS AND MUCH MORE...

www.platinumairsuspension.com | 714-871-2424

ABOUT US

HOW WE GOT STARTED, WHERE WE ARE HEADED, AND WHAT WE'RE ALL ABOUT



Today it is common to find air suspension systems on motorcycles, even as OEM equipment, but one of the forerunners in the market is Platinum Air Suspension. The Southern California based company has air ride systems for all Harley Davidson, Victory, Can-Am, Metric, Street Bikes, Boss Hoss, Indian and custom applications.

Platinum Air Suspension was founded by Oscar Sanchez when he began working on a custom bike project and developed his own air ride system. As is often the way in the motorcycle industry, people noticed Oscar's improved ride, and asked him to work on their bikes as well. In 2004 Oscar went into business full-time building his air ride systems under the name Platinum Air Suspension. As the company grew Oscar employed Mike Ferris to take care of sales and assembly, in effect doubling the company's workforce. When the opportunity to buy the business from Oscar became available in 2007 Mike took the leap, and became the owner rather than just an employee. Under Mike's control Platinum Air Suspension moved locations, added staff and is now turning over almost a million dollars a year as it services 600+ dealers worldwide with fitment options that cover not only H-D but also Victory, Indian, and Boss Hoss, not to mention metric and custom applications.

By providing his customers with a wide range of choices, Mike has been able to grow his business and continue to expand into more markets. Today Platinum Air suspension makes 80 percent of its sales to the domestic and Canadian markets while the balance comes from exports with a particular emphasis on Australia, Germany and France. While the company has explored new markets, dealer direct sales and supports an online store.

It is these dealers who benefit most from the constant product development undertaken by Mike and his team at their manufacturing plant in Fullerton, California. While the business constantly monitors the yearly changes made to bike models by manufacturers in order to keep up with changes to schematics, specifications, and even the necessary space for the onboard compressors, Platinum also offers custom build services for when a stock application is not available or applicable.

It is not just individual customers that have taken advantage of Platinum Air Suspension's custom builds. Paul Yaffe's Bagger Nation had tried various air ride systems over the years before it tried a Platinum kit. The team at Bagger Nation was so impressed with the system it received from Platinum that they now have their 'Lay'd Out' kits made exclusively by Platinum. The exclusive design for Bagger Nation is the lowest traveling shock made by the company, and goes from 13in extended to 9.25in dropped offering a 3.75in range. This is just a sample of the development and types of work that drives Platinum Air Suspension for more than 10 years. Stories like these demonstrate how the company continues to grow as it expands its product lines and continues to venture into international markets.

Remember at Platinum Air Suspension - It's All About The Ride



MIKE FERRIS THE OWNER OF PLATINUM AIR SUSPENSION (LEFT) WITH COMPANY R&D MANAGER EDGAR ARAYA

BLEED FEED TECHNOLOGY



"It's all about the Ride"

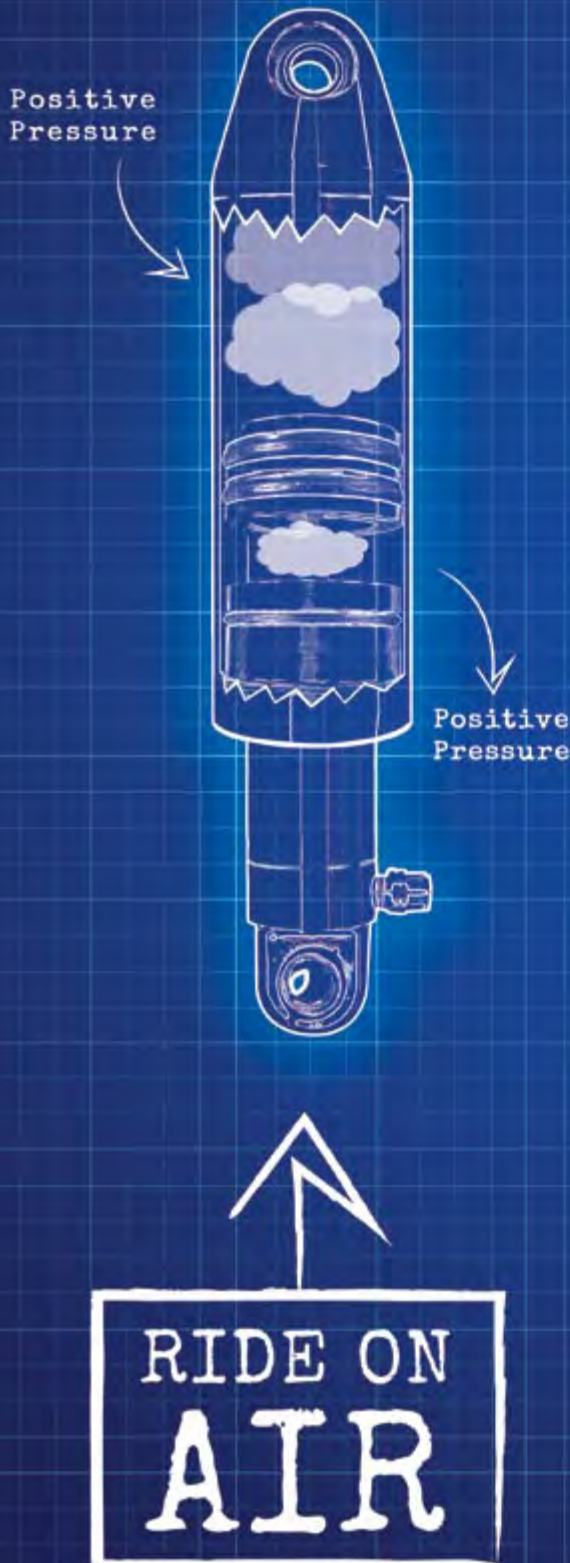

One of the company's bestselling packages is its 'Bleed Feed' system, which allows the rider to control both ride height and rebound. Developed by Platinum, Bleed Feed technology raises the bar as the industry's best air suspension riding system. This technology allows you to control both front pressure & back pressure for the ultimate custom riding experience.

"With this technology riders can have a lowered look & comfortable ride at any desired height."

- Mike Ferris

Our products have been put to the test by thousands of customers over our 10+ years in the motorcycle industry, and we will continue our dedication to manufacturing reliable and quality products for years to come. At Platinum we believe every customer is unique, and our Bleed Feed system allows you to make your ride equally unique.

Bleed Feed systems are available for H-D, V-Twins, Metric, Cruisers, Street Bikes, & Custom Applications and includes air cylinders machined from 6061 T-6 billet aluminum. An air-control valve, DOT- approved 1/4" line and fitting, plus switch harness, air compressor, hardware and line cutter. The system is also 100% made in the U.S.A. and comes complete with a limited one year warranty.

For some customers less is more, and for them Platinum also provides our Simple System, made from the same quality components as the Bleed Feed system. This system allows a rider to control their ride height with positive lift, but doesn't provide the same rebound control as Bleed Feed. Platinum Air Suspension offers a Simple system for most H-D, V-Twins, Metric, Cruisers, Street Bikes & Custom Applications.

Platinum's Bleed Feed Air Ride Systems are available for all Harley Davidson, Indian, Victory, Can-Am, Metric, Street Bikes, Boss Hoss, and custom applications.

NEW PRODUCT & OPTIONS

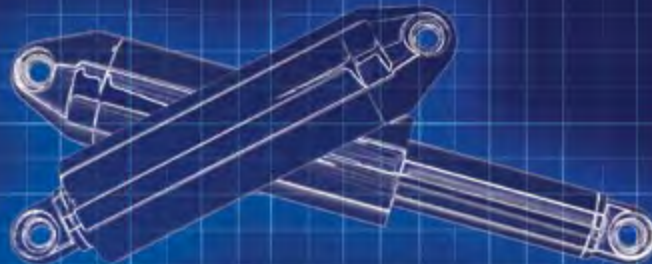

FL Long Travel Option

Min. retracted 9.25 inch and
max. extended 13.5 inch

NEW



Brand New FL Shock

We've completely re-tooled this
shock from top to bottom making it
even better than before.



NEW

Black Out Option

Customers' now have the option to choose between chrome
and black. Everything is blacked out from cylinder to
rod. Available for FL, V-RODS, Dyna, Sportster and Boss
Hoss! It's tough and can handle the wear and tear.





More Options



Shocks for
2014 to Current
Indians



High Gloss
Black for
Twin Cam / Softail
models



High Gloss
Black for
Evo / Softail
models

Front Air Ride

NEW



Compressors



Accessories



We now carry all the miscellaneous options
to build a one off air ride kit.

HARLEY DAVIDSON FLH'S / FLHT'S SYSTEMS

FITS ROAD GLIDE, STREET
GLIDE, ROAD KING, ELECTRA
GLIDE, CVO, TRIKE AND ALL
H-D TOURING MODELS.

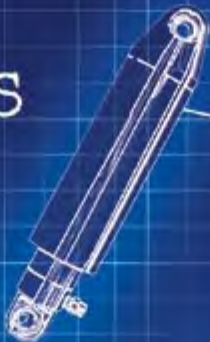

Blacked Out Rod

High Gloss Black

Custom Colors Available

Long Travel

9.25" 13" 13.5"

Bleed Feed

NEW

PAS-1702-FLH
PAS-1702-FLH-B

Min. Retracted 9 1/4"
Max. Extended 13"
Rear Lift: 3 3/4"
Shock Travel: 3 3/4"
Diameter: 2 1/2"



*ABS applications may vary due to installation.



Kit includes the following: (2) Air cylinders machined from 6061 T-6 billet aluminum, air-control valve, DOT-approved 1/4" line and fittings, air compressor, switch harness, hardware and line cutter.

Simple



Simple

PAS-1686-RKD
 PAS-1686-RKD-B

NEW

Min. Retracted 9 1/4"
 Max. Extended 13"
 Rear Lift: 3 3/4"
 Shock Travel: 3 3/4"
 Diameter: 2 1/2"



*ABS applications may vary due to installation.



Kit includes the following: (2) Air cylinders machined from 6061 T-6 billet aluminum, air-control valve, DOT-approved 1/4" line and fittings, air compressor, switch harness, hardware and line cutter.

Old Style Shocks & Custom Colors Available
 Call Us!



Long Travel

PAS-1702-FLH-SLT
 PAS-1702-FLH-SLT-B

NEW

Min. Retracted 9 1/4"
 Max. Extended 13.5"
 Rear Lift: 4 1/4"
 Shock Travel: 4 1/4"
 Diameter: 2 1/2"



*ABS applications may vary due to installation.



Kit includes the following: (2) Air cylinders machined from 6061 T-6 billet aluminum, air-control valve, DOT-approved 1/4" line and fittings, air compressor, switch harness, hardware and line cutter.

Bike Photo
 Courtesy of
 Rudy Jumilla



HARLEY DAVIDSON FLH'S / FLHT'S FRONT AND REAR AIR RIDE PACKAGES



NEW

*ABS applications may vary due to installation.



PAS-FRTC



Kit includes the following: (2) Air cylinders, air-control valve, DOT-approved 1/4" line and fittings, air compressor, and hardware.

HARLEY DAVIDSON TWIN CAM / SOFTAIL FRONT AND REAR AIR RIDE PACKAGES



*ABS applications may vary due to installation.

HARLEY DAVIDSON EVO / SOFTAIL FRONT AND REAR AIR RIDE PACKAGES



Bike Photo
Courtesy of
Rudy Jumilla



"It's all about the Ride"

HARLEY DAVIDSON TWIN CAM / SOFTAIL SYSTEMS

FITS SOFTTAIL SLIM, FAT BOY,
AND ALL 2000 TO CURRENT
H-D SOFTTAIL MODELS.

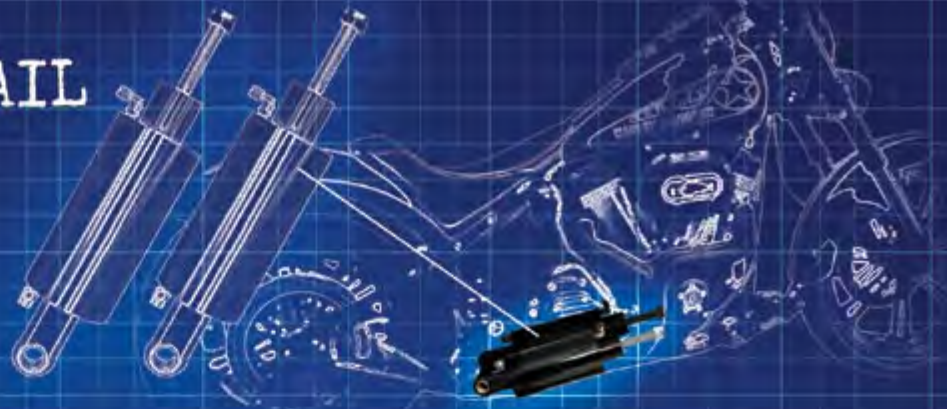

Bleed Feed

PAS-0000-TBF
PAS-0000-TBF-B

Min. Retracted 9"
Max. Extended 11"
Rear Lift: 5"
Shock Travel: 2"
Diameter: 2 3/4"



*ABS applications may vary due to installation.



Kit includes the following: (2) Air cylinders machined from 6061 T-6 billet aluminum, the rods and end caps are machined from stainless steel, steel splash guard, air-control valve, DOT-approved 1/4" line and fittings, air compressor, switch harness, hardware and line cutter.

← High Gloss Black

Simple

PAS-0000-ST
PAS-0000-ST-B

Min. Retracted 9"
Max. Extended 11"
Rear Lift: 5"
Shock Travel: 2"
Diameter: 2 3/4"



*ABS applications may vary due to installation.



Kit includes the following: (2) Air cylinders machined from 6061 T-6 billet aluminum, the rods and end caps are machined from stainless steel, steel splash guard, air-control valve, DOT-approved 1/4" line and fittings, air compressor, switch harness, hardware and line cutter.



Bike Photo
Courtesy of
Joe Bueno

HARLEY DAVIDSON EVO / SOFTAIL SYSTEMS

FITS ALL 1986 TO 1999 EVO / SOFTAIL
MODELS.

BLEED FEED TECHNOLOGY
PLATINUM
AIR SUSPENSION

"It's all about the Ride"



Bleed Feed

PAS-8699-EBF
PAS-8699-EBF-B

Min. Retracted 11"
Max. Extended 13"
Rear Lift: 5"
Shock Travel: 2"
Diameter: 2 3/4"



Simple

PAS-8699-SE
PAS-8699-SE-B

Min. Retracted 11"
Max. Extended 13"
Rear Lift: 5"
Shock Travel: 2"
Diameter: 2 3/4"



Kit includes the following: (2) Air cylinders machined from 6061 T-6 billet aluminum, the rods and end caps are machined from stainless steel, steel splash guard, air-control valve, DOT-approved 1/4" line and fittings, air compressor, switch harness, hardware and line cutter.

Kit includes the following: (2) Air cylinders machined from 6061 T-6 billet aluminum, the rods and end caps are machined from stainless steel, steel splash guard, air-control valve, DOT-approved 1/4" line and fittings, air compressor, switch harness, hardware and line cutter.



← High Gloss Black

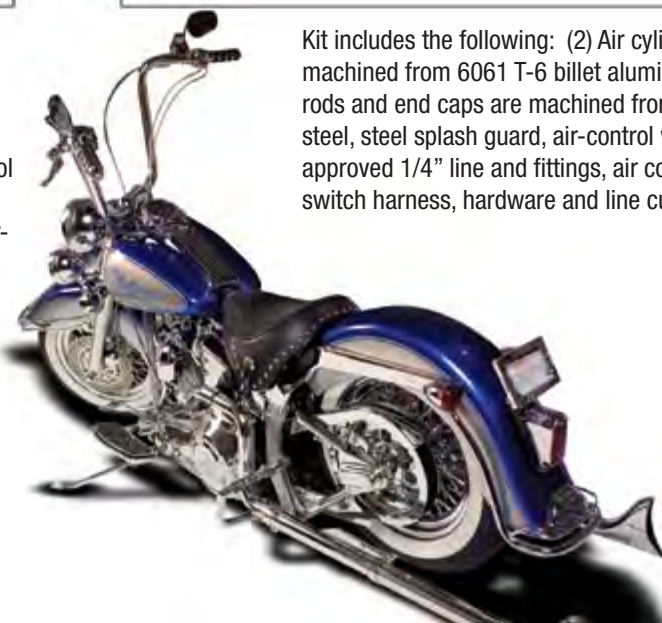

HARLEY DAVIDSON V-ROD SYSTEMS

FITS V-ROD MUSCLE, NIGHT
ROD SPECIAL AND ALL H-D
V-ROD MODELS.



Bleed Feed PAS-1702-VRBF PAS-1702-VRBF-B

NEW

Min. Retracted 10 3/4"
Max. Extended 13"
Rear Lift: 2 1/4"
Shock Travel: 2 1/4"
Diameter: 2 1/2"



Simple PAS-1702-VRD PAS-1702-VRD-B

NEW

Min. Retracted 10 3/4"
Max. Extended 13"
Rear Lift: 2 1/4"
Shock Travel: 2 1/4"
Diameter: 2 1/2"



Kit includes the following: (2) Air cylinders machined from 6061 T-6 billet aluminum, air-control valve, DOT-approved 1/4" line and fittings, air compressor, switch harness, hardware and line cutter.

Kit includes the following: (2) Air cylinders machined from 6061 T-6 billet aluminum, air-control valve, DOT-approved 1/4" line and fittings, air compressor, switch harness, hardware and line cutter.



← High Gloss Black
w/ Black Rod

← Satin Black
w/ Black Rod

← Custom Colors
Available

10.75" 13"



GR Customs

HARLEY DAVIDSON SPORTSTER / DYNA SYSTEMS

FITS SUPERLOW, IRON 883, 1200
CUSTOM, FORTY-EIGHT, SUPERLOW
1200T, ROADSTER, STREET BOB,
LOW RIDER, FAT BOB, WIDE GLIDE
AND ALL H-D SPORTSTER AND
DYNA MODELS.

BLEED FEED TECHNOLOGY
PLATINUM
AIR SUSPENSION

"It's all about the Ride"



Simple

PAS-1686-RKD
& PAS-1702-DD

Min. Retracted 9 1/4"
Max. Extended 13"
Rear Lift: 3 3/4"
Shock Travel: 3 3/4"
Diameter: 2 1/2"



*Specifications may vary

High Gloss Black
w/ Black Rod

Custom Colors
Available



It's All About The Ride!

Kit includes the following: (2) Air cylinders machined from 6061
T-6 billet aluminum, air-control valve, DOT-approved 1/4" line and
fittings, air compressor, switch harness, hardware and line cutter.



High Gloss Black
w/ Black Rod



INDIAN BAGGER / TOURING SYSTEMS (2014 TO CURRENT)

FITS INDIAN CHIEF, DARK HORSE,
CLASSIC, VINTAGE, SPRINGFIELD,
CHIEFTAIN, ROADMASTER AND ALL
BAGGER AND TOURING MODELS.

BLEED FEED TECHNOLOGY
PLATINUM
AIR SUSPENSION

"It's all about the Ride"



Bleed Feed

PAS-ICBF-2014PR
PAS-ICBF-2014PR-B

Min. Retracted 10 1/4"
Max. Extended 12 1/4"
Rear Lift: 4"
Shock Travel: 2"
Diameter: 3 1/4"



Kit includes the following: (1) Air cylinders machined from 6061 T-6 billet aluminum, air-control valve, DOT-approved 1/4" line and fittings, air compressor, switch harness, hardware and line cutter.

Simple

PAS-SSIC-2014PR
PAS-SSIC-2014PR-B

Min. Retracted 10 1/4"
Max. Extended 12 1/4"
Rear Lift: 4"
Shock Travel: 2"
Diameter: 3 1/4"



Kit includes the following: (1) Air cylinders machined from 6061 T-6 billet aluminum, air-control valve, DOT-approved 1/4" line and fittings, air compressor, switch harness, hardware and line cutter.



**BIKE PHOTO COURTESY
OF PEDRO PENA**



INDIAN
2014 TO CURRENT
AIR RIDE KITS



INDIAN CHIEF SYSTEMS (2003 TO 2011)

FITS INDIAN CHIEF MADE
FROM 2003 TO 2011.



Bleed Feed

PAS-1732-ICBF
PAS-1732-ICBF-B

Min. Retracted 8 1/4"
Max. Extended 10 1/4"
Rear Lift: 4"
Shock Travel: 2"
Diameter: 3 1/4"



Kit includes the following: (1) Air cylinders machined from 6061 T-6 billet aluminum, air-control valve, DOT-approved 1/4" line and fittings, air compressor, switch harness, hardware and line cutter.

Simple

PAS-1732-SSIC
PAS-1732-SSIC-B

Min. Retracted 8 1/4"
Max. Extended 10 1/4"
Rear Lift: 4"
Shock Travel: 2"
Diameter: 3 1/4"



Kit includes the following: (1) Air cylinders machined from 6061 T-6 billet aluminum, air-control valve, DOT-approved 1/4" line and fittings, air compressor, switch harness, hardware and line cutter.

Also Available In Custom Colors



INDIAN
CHIEF
SYSTEMS
(1999 TO 2002)

FITS INDIAN CHIEF MADE
FROM 1999 TO 2002.



BLEED FEED TECHNOLOGY
PLATINUM
AIR SUSPENSION

"It's all about the Ride"

Bleed Feed

PAS-8699-EBF
PAS-8699-EBF-B

Min. Retracted 8"
Max. Extended 10"
Rear Lift: 4"
Shock Travel: 2"
Diameter: 3 1/4"



Kit includes the following: (2) Air cylinders machined from 6061 T-6 billet aluminum, the rods and end caps are machined from stainless steel, steel splash guard, air-control valve, DOT-approved 1/4" line and fittings, air compressor, switch harness, hardware and line cutter.



← High Gloss Black

Simple

PAS-8699-SE
PAS-8699-SE-B

Min. Retracted 8"
Max. Extended 10"
Rear Lift: 4"
Shock Travel: 2"
Diameter: 3 1/4"



Kit includes the following: (2) Air cylinders machined from 6061 T-6 billet aluminum, the rods and end caps are machined from stainless steel, steel splash guard, air-control valve, DOT-approved 1/4" line and fittings, air compressor, switch harness, hardware and line cutter.

LET IT RIDE
CUSTOM CYCLES



VICTORY CRUISER KITS

AIR RIDE FOR VICTORY CRUISERS,
VEGAS 8-BALL, HIGH-BALL,
GUNNER, VEGAS, JACKPOT, KINGPIN,
HAMMER AND HAMMER S.



Bleed Feed

PAS-1723-VICBF
PAS-1723-VICBF-B

Min. Retracted 12 1/4"
Max. Extended 14 1/4"
Rear Lift: 4"
Shock Travel: 2"
Diameter: 3 1/4"



Kit includes the following: (1) Air cylinders machined from 6061 T-6 billet aluminum, mounting bracket, air-control valve, DOT-approved 1/4" line and fittings, air compressor, switch harness, hardware and line cutter.

Simple

PAS-1723-VICST
PAS-1723-VICST-B

Min. Retracted 12 1/4"
Max. Extended 14 1/4"
Rear Lift: 4"
Shock Travel: 2"
Diameter: 3 1/4"

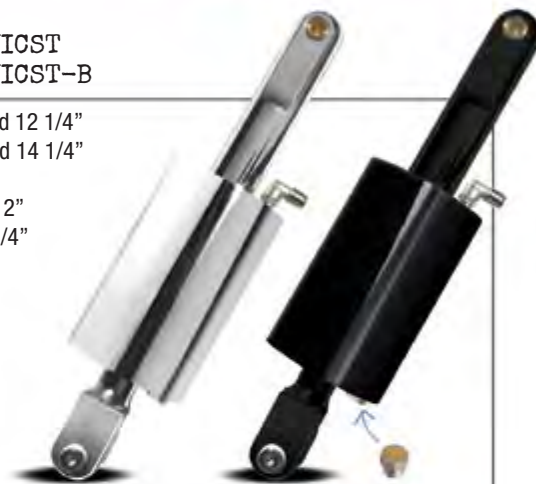

Kit includes the following: (1) Air cylinders machined from 6061 T-6 billet aluminum, mounting bracket, air-control valve, DOT-approved 1/4" line and fittings, air compressor, switch harness, hardware and line cutter.



Bike Photo
Courtesy of
Ben Alberts



VICTORY BAGGER KITS

AIR RIDE FOR VICTORY BAGGERS,
TOURING, CROSS COUNTRY,
MAGNUM, MANGUM X-1, VISION
AND CROSS COUNTRY TOUR.

BLEED FEED TECHNOLOGY
PLATINUM
AIR SUSPENSION

"It's all about the Ride"



Bleed Feed

PAS-1723-VICST
PAS-1723-VICST-B

Min. Retracted 11"
Max. Extended 13"
Rear Lift: 4"
Shock Travel: 2"
Diameter: 3 1/4"



Simple

PAS-1723-VCBS
PAS-1723-VCBS-B

Min. Retracted 11"
Max. Extended 13"
Rear Lift: 4"
Shock Travel: 2"
Diameter: 3 1/4"



Kit includes the following: (1) Air cylinders machined from 6061 T-6 billet aluminum, air-control valve, DOT-approved 1/4" line and fittings, air compressor, switch harness, hardware and line cutter.

Kit includes the following: (1) Air cylinders machined from 6061 T-6 billet aluminum, air-control valve, DOT-approved 1/4" line and fittings, air compressor, switch harness, hardware and line cutter.

Also Available In
Custom Colors

High Gloss Black
w/ Black Rod



11" 13"



Bike Photo
Courtesy of
Carlos Vega



NEW

CUSTOM COLOR ANODIZED AND BALL MILL CUT OPTIONS

At Platinum Air Suspension, we strive to bring you the latest trend and custom options for your ride. After a ton of research and development we are proud to offer custom color anodized finish with ball mill cut for your mono shock. Please keep in mind, that this option is available for all metric and street bikes. Please feel free to call to see what options are available for your motorcycle.

Call (714) 871-2424 to order
these options for your ride!





SUZUKI HAYABUSA KITS

AIR RIDE FOR SUZUKI HAYABUSA
OR GSX1300R.



Bleed Feed

PAS-1723-VICBF
PAS-1723-VICBF-B

Min. Retracted 12 1/4"
Max. Extended 14 1/4"
Rear Lift: 4"
Shock Travel: 2"
Diameter: 3 1/4"



Kit includes the following: (1) Air cylinders machined from 6061 T-6 billet aluminum, air-control valve, DOT-approved 1/4" line and fittings, air compressor, switch harness, hardware and line cutter.

Simple

PAS-1723-VICST
PAS-1723-VICST-B

Min. Retracted 12 1/4"
Max. Extended 14 1/4"
Rear Lift: 4"
Shock Travel: 2"
Diameter: 3 1/4"



Kit includes the following: (1) Air cylinders machined from 6061 T-6 billet aluminum, air-control valve, DOT-approved 1/4" line and fittings, air compressor, switch harness, hardware and line cutter.

Available
In Custom
Colors
And / Or
Mill Cut



"Resident Evil" by
Uptown GrafX Custom Paint



SUZUKI M109 & BOULEVARD KITS

AIR RIDE FOR SUZUKI M109 &
BOULEVARD C109R, C90, C50,
M109R, M50, S40, S50, S83 &
INTRUDER.



BLEED FEED TECHNOLOGY
PLATINUM
AIR SUSPENSION

"It's all about the Ride"

Bleed Feed

PAS-1723-VCBBF
PAS-1723-VCBBF-B

Min. Retracted 10 1/2"
Max. Extended 12 1/2"
Rear Lift: 4"
Shock Travel: 2"
Diameter: 3 1/4"



Simple

PAS-1723-VCBS
PAS-1723-VCBS-B

Min. Retracted 10 1/2"
Max. Extended 12 1/2"
Rear Lift: 4"
Shock Travel: 2"
Diameter: 3 1/4"



Kit includes the following: (1) Air cylinders machined from 6061 T-6 billet aluminum, mounting bracket, air-control valve, DOT-approved 1/4" line and fittings, air compressor, switch harness, hardware and line cutter.

Kit includes the following: (1) Air cylinders machined from 6061 T-6 billet aluminum, mounting bracket, air-control valve, DOT-approved 1/4" line and fittings, air compressor, switch harness, hardware and line cutter.

Available In Custom
Colors And / Or Mill Cut

← High Gloss Black



William Weldon
M109R

SUZUKI GSX-R (STOCK)

AIR RIDE FOR SUZUKI GSX-R125,
GSX-R150, GSX-R600 GSX-R750
GSX-R1000 AND ALL GSX-R MODELS.



Bleed Feed

PAS-1724-BFSB
PAS-1724-BFSB-B

Min. Retracted 9 1/2"
Max. Extended 11 1/2"
Rear Lift: 4"
Shock Travel: 2"
Diameter: 2 3/4"



Kit includes the following: (1) Air cylinders machined from 6061 T-6 billet aluminum, mounting bracket, air-control valve, DOT-approved 1/4" line and fittings, air compressor, switch harness, hardware and line cutter.

Simple

PAS-1724-SSSB
PAS-1724-SSSB-B

Min. Retracted 9 1/2"
Max. Extended 11 1/2"
Rear Lift: 4"
Shock Travel: 2"
Diameter: 2 3/4"



Kit includes the following: (1) Air cylinders machined from 6061 T-6 billet aluminum, mounting bracket, air-control valve, DOT-approved 1/4" line and fittings, air compressor, switch harness, hardware and line cutter.



Bike Photo
Courtesy of
Beezee



SUZUKI GSX-R (FAT TIRE)

AIR RIDE FOR SUZUKI GSX-R125,
GSX-R150, GSX-R600 GSX-R750
GSX-R1000 AND ALL GSX-R MODELS.

BLEED FEED TECHNOLOGY
PLATINUM
AIR SUSPENSION

"It's all about the Ride"



Bleed Feed

PAS-1724-BFSB-BC
PAS-1724-BFSB-BC-B

Min. Retracted 9 1/2"
Max. Extended 11 1/2"
Rear Lift: 4"
Shock Travel: 2"
Diameter: 3 1/4"



Kit includes the following: (1) Air cylinders machined from 6061 T-6 billet aluminum, mounting bracket, air-control valve, DOT-approved 1/4" line and fittings, air compressor, switch harness, hardware and line cutter.

Simple

PAS-1724-SSSB-BC
PAS-1724-SSSB-BC-B

Min. Retracted 9 1/2"
Max. Extended 11 1/2"
Rear Lift: 4"
Shock Travel: 2"
Diameter: 3 1/4"



Kit includes the following: (1) Air cylinders machined from 6061 T-6 billet aluminum, mounting bracket, air-control valve, DOT-approved 1/4" line and fittings, air compressor, switch harness, hardware and line cutter.



Bike Photo
Courtesy
Shannon A.



KAWASAKI NINJA ZX-10R & ZX-14R KITS

AIR RIDE FOR KAWASAKI ZX-10R &
ZX-14R AND ALL KAWASAKI NINJA
MODELS.

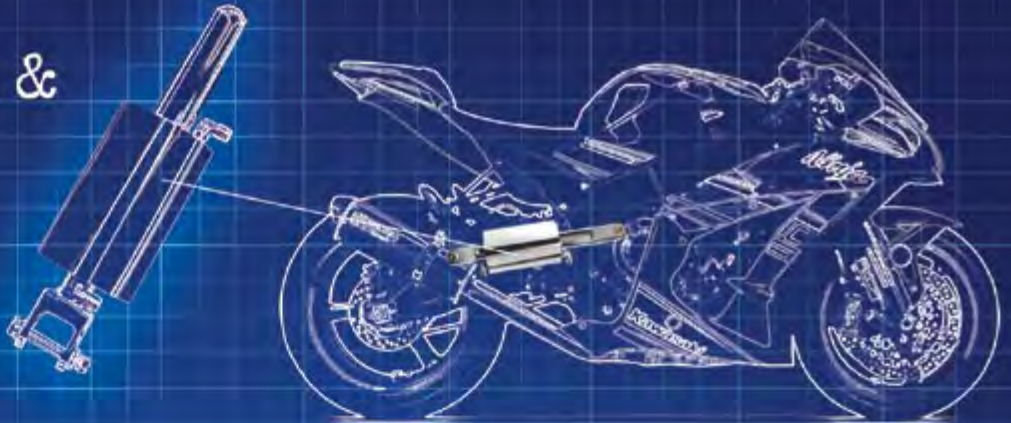

Bleed Feed

PAS-1723-ZX-BF
PAS-1723-ZX-BF-B

Min. Retracted 12 1/4"
Max. Extended 14 1/4"
Rear Lift: 4" to 5"
Shock Travel: 2"
Diameter: 3 1/4"



Kit includes the following: (1) Air cylinders machined from 6061 T-6 billet aluminum, mounting bracket, air-control valve, DOT-approved 1/4" line and fittings, air compressor, switch harness, hardware and line cutter.

Simple

PAS-1723-RST
PAS-1723-RST-B

Min. Retracted 12 1/4"
Max. Extended 14 1/4"
Rear Lift: 4" to 5"
Shock Travel: 2"
Diameter: 3 1/4"



Kit includes the following: (1) Air cylinders machined from 6061 T-6 billet aluminum, mounting bracket, air-control valve, DOT-approved 1/4" line and fittings, air compressor, switch harness, hardware and line cutter.



Bike Photo
Courtesy of
Cody Raza



YAMAHA V STAR KITS

AIR RIDE FOR DRAGSTAR / V STAR CLASSIC, CUSTOM, SILVERADO, 950 TOURER, 1100, 1100 CLASSIC, 1100 CUSTOM, 1100 SILVERADO, 1300, AND 1300 TOURER V STAR MOTORCYCLES.

BLEED FEED TECHNOLOGY
PLATINUM
AIR SUSPENSION

"It's all about the Ride"



Bleed Feed

PAS-1713-BFV
PAS-1713-BFV-B

Min. Retracted 9 1/2"
Max. Extended 11 1/2"
Rear Lift: 4"
Shock Travel: 2"
Diameter: 2 3/4"



Kit includes the following: (1) Air cylinders machined from 6061 T-6 billet aluminum, mounting bracket, air-control valve, DOT-approved 1/4" line and fittings, air compressor, switch harness, hardware and line cutter.

Simple

PAS-1713-VSST
PAS-1713-VSST-B

Min. Retracted 9 1/2"
Max. Extended 11 1/2"
Rear Lift: 4"
Shock Travel: 2"
Diameter: 2 3/4"



Kit includes the following: (1) Air cylinders machined from 6061 T-6 billet aluminum, mounting bracket, air-control valve, DOT-approved 1/4" line and fittings, air compressor, switch harness, hardware and line cutter.



YAMAHA YZF-R1

AIR RIDE FOR YAMHA YZF-R1,
OPEN CLASS SPORT BIKE,
SUPERBIKE, AND ALL R1 MODELS.



Bleed Feed

PAS-1668-RBF
PAS-1668-RBF-B

Min. Retracted 9 1/2"
Max. Extended 11 1/2"
Rear Lift: 4" to 5"
Shock Travel: 2"
Diameter: 2 3/4"



Simple

PAS-1668-SST
PAS-1668-SST-B

Min. Retracted 9 1/2"
Max. Extended 11 1/2"
Rear Lift: 4" to 5"
Shock Travel: 2"
Diameter: 2 3/4"



Kit includes the following: (1) Air cylinders machined from 6061 T-6 billet aluminum, mounting bracket, air-control valve, DOT-approved 1/4" line and fittings, air compressor, switch harness, hardware and line cutter.

Kit includes the following: (1) Air cylinders machined from 6061 T-6 billet aluminum, mounting bracket, air-control valve, DOT-approved 1/4" line and fittings, air compressor, switch harness, hardware and line cutter.



Bike Photo Courtesy of Wendell Johnson
Painted by Nuematic Addict



YAMAHA YZF-R6

AIR RIDE FOR YAMAHA YZF-R6
600 CLASS SPORT BIKE MODELS.



Bleed Feed

PAS-1668-RBF
PAS-1668-RBF-B

Min. Retracted 9 1/2"
Max. Extended 11 1/2"
Rear Lift: 4" to 5"
Shock Travel: 2"
Diameter: 2 3/4"



Kit includes the following: (1) Air cylinders machined from 6061 T-6 billet aluminum, mounting bracket, air-control valve, DOT-approved 1/4" line and fittings, air compressor, switch harness, hardware and line cutter.

Simple

PAS-1668-SST
PAS-1668-SST-B

Min. Retracted 9 1/2"
Max. Extended 11 1/2"
Rear Lift: 4" to 5"
Shock Travel: 2"
Diameter: 2 3/4"



Kit includes the following: (1) Air cylinders machined from 6061 T-6 billet aluminum, mounting bracket, air-control valve, DOT-approved 1/4" line and fittings, air compressor, switch harness, hardware and line cutter.



Bike Photo
Courtesy of
Rick at
LA Kustomz



YAMAHA STRYKER KITS

AIR RIDE FOR HONDA STRYKER
MODELS.



Bleed Feed

PAS-1713-BFYSS
PAS-1713-BFYSS-B

Min. Retracted 10"
Max. Extended 12"
Rear Lift: 4" to 5"
Shock Travel: 2"
Diameter: 2 3/4"



Kit includes the following: (1) Air cylinders machined from 6061 T-6 billet aluminum, mounting bracket, air-control valve, DOT-approved 1/4" line and fittings, air compressor, switch harness, hardware and line cutter.



Simple

PAS-1713-SYSS
PAS-1713-SYSS-B

Min. Retracted 10"
Max. Extended 12"
Rear Lift: 4" to 5"
Shock Travel: 2"
Diameter: 2 3/4"



Kit includes the following: (1) Air cylinders machined from 6061 T-6 billet aluminum, mounting bracket, air-control valve, DOT-approved 1/4" line and fittings, air compressor, switch harness, hardware and line cutter.



HONDA
 FURY, SABRE,
 SHADOW &
 STATELINE
 KITS

AIR RIDE FOR THESE HONDA
 MODELS.



Bleed Feed

PAS-1723-HFBF
 PAS-1723-HFBF-B

Min. Retracted 10 3/4"
 Max. Extended 12 3/4"
 Rear Lift: 4"
 Shock Travel: 2"
 Diameter: 3 1/4"



Kit includes the following: (1) Air cylinders machined from 6061 T-6 billet aluminum, mounting bracket, air-control valve, DOT-approved 1/4" line and fittings, air compressor, switch harness, hardware and line cutter.

Simple

PAS-1723-HFS
 PAS-1723-HFS-B

Min. Retracted 10 3/4"
 Max. Extended 12 3/4"
 Rear Lift: 4"
 Shock Travel: 2"
 Diameter: 3 1/4"



Kit includes the following: (1) Air cylinders machined from 6061 T-6 billet aluminum, mounting bracket, air-control valve, DOT-approved 1/4" line and fittings, air compressor, switch harness, hardware and line cutter.



Bike Photo
 Courtesy of
 Scott Courville

HONDA CBR (STOCK)

AIR RIDE FOR HONDA CBR 250, 300, 400, 500, 600, HURRICANE, 650F, 750F HURRICANE / SUPER AERO, 900RR FIREBLADE, 893 CC, 919 CC, 929RR, FIREBLADE, 954RR, 1000RR, 1000F, 1100XX SUPER BLACKBIRD MODELS.



Bleed Feed

PAS-1723-BFS
PAS-1723-BFS-B

Min. Retracted 9 1/2"
Max. Extended 11 1/2"
Rear Lift: 4"
Shock Travel: 2"
Diameter: 2 3/4"



Kit includes the following: (1) Air cylinders machined from 6061 T-6 billet aluminum, mounting bracket, air-control valve, DOT-approved 1/4" line and fittings, air compressor, switch harness, hardware and line cutter.

Simple

PAS-1723-HST
PAS-1723-HST-B

Min. Retracted 9 1/2"
Max. Extended 11 1/2"
Rear Lift: 4"
Shock Travel: 2"
Diameter: 2 3/4"



Kit includes the following: (1) Air cylinders machined from 6061 T-6 billet aluminum, mounting bracket, air-control valve, DOT-approved 1/4" line and fittings, air compressor, switch harness, hardware and line cutter.



JEEPERS
Racing



HONDA CBR (FAT TIRE)

AIR RIDE FOR HONDA CBR 250, 300, 400, 500, 600, HURRICANE, 650F, 750F HURRICANE / SUPER AERO, 900RR FIREBLADE, 893 CC, 919 CC, 929RR, FIREBLADE, 954RR, 1000RR, 1000F, 1100XX SUPER BLACKBIRD MODELS.



BLEED FEED TECHNOLOGY
PLATINUM
AIR SUSPENSION

"It's all about the Ride"

HONDA

Bleed Feed

PAS-1723-HCBF-BC
PAS-1723-HCBF-BC-B

Min. Retracted 9 1/2"
Max. Extended 11 1/2"
Rear Lift: 4"
Shock Travel: 2"
Diameter: 3 1/4"



Kit includes the following: (1) Air cylinders machined from 6061 T-6 billet aluminum, mounting bracket, air-control valve, DOT-approved 1/4" line and fittings, air compressor, switch harness, hardware and line cutter.

Simple

PAS-1723-HCST-BC
PAS-1723-HCST-BC-B

Min. Retracted 9 1/2"
Max. Extended 11 1/2"
Rear Lift: 4"
Shock Travel: 2"
Diameter: 3 1/4"



Kit includes the following: (1) Air cylinders machined from 6061 T-6 billet aluminum, mounting bracket, air-control valve, DOT-approved 1/4" line and fittings, air compressor, switch harness, hardware and line cutter.



CAN-AM SPYDER ROADSTER KITS (REAR)

AIR RIDE FOR CAN-AM SPYDER
THREE-WHEELED MOTORCYCLE
MANUFACTURED BY BOMBARDIER
RECREATIONAL PRODUCTS.

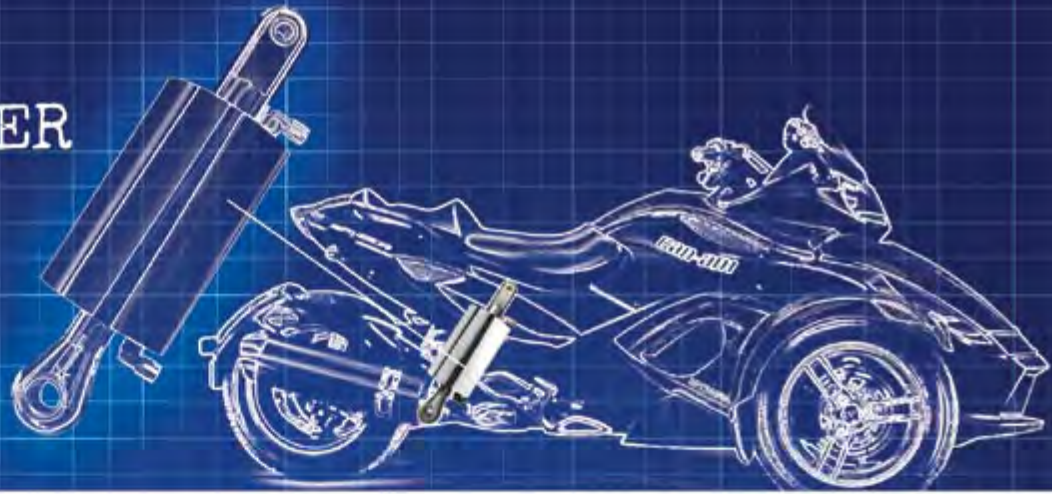

Bleed Feed

PAS-SPYR-BF
PAS-SPYR-BF-B

Min. Retracted 10"
Max. Extended 12"
Rear Lift: 5"
Shock Travel: 2"
Diameter: 2 3/4"

2013 to Present
Min. Retracted 11"
Max. Extended 13"
Rear Lift: 5"
Shock Travel: 2"
Diameter: 2 3/4"



Kit includes the following: (1) Air cylinders machined from 6061 T-6 billet aluminum, mounting bracket, air-control valve, DOT-approved 1/4" line and fittings, air compressor, switch harness, hardware and line cutter.

Simple

PAS-SPYR-S
PAS-SPYR-S-B

Min. Retracted 10"
Max. Extended 12"
Rear Lift: 5"
Shock Travel: 2"
Diameter: 2 3/4"

2013 to Present
Min. Retracted 11"
Max. Extended 13"
Rear Lift: 5"
Shock Travel: 2"
Diameter: 2 3/4"



Kit includes the following: (1) Air cylinders machined from 6061 T-6 billet aluminum, mounting bracket, air-control valve, DOT-approved 1/4" line and fittings, air compressor, switch harness, hardware and line cutter.



Bike Photo
"Dark Knight"
Courtesy of
Tyler Hughey



CAN-AM SPYDER ROADSTER KITS (FRONT)

BLEED FEED TECHNOLOGY
PLATINUM
AIR SUSPENSION

"It's all about the Ride"



Bleed Feed

PAS-SPYRFT-BF
PAS-SPYRFT-BF-B

Min. Retracted 15 1/4"
Max. Extended 17 1/4"
Rear Lift: 5"
Shock Travel: 2"
Diameter: 2 3/4"



Kit includes the following: (2) Air cylinders machined from 6061 T-6 billet aluminum, air-control valve, DOT-approved 1/4" line and fittings, air compressor, switch harness, hardware and line cutter.

Simple

PAS-SPYRFT-S
PAS-SPYRFT-S-B

Min. Retracted 15 1/4"
Max. Extended 17 1/4"
Rear Lift: 5"
Shock Travel: 2"
Diameter: 2 3/4"



Kit includes the following: (2) Air cylinders machined from 6061 T-6 billet aluminum, air-control valve, DOT-approved 1/4" line and fittings, air compressor, switch harness, hardware and line cutter.



"Dark Knight"
painted by
Uptown Grafx
Custom Paint



BOSS HOSS BHC-3 & BHC-9 SYSTEMS

FITS ALL BOSS HOSS CYCLES HIGH-PERFORMANCE MOTORCYCLES & TRIKES EQUIPPED WITH V8 ENGINE.

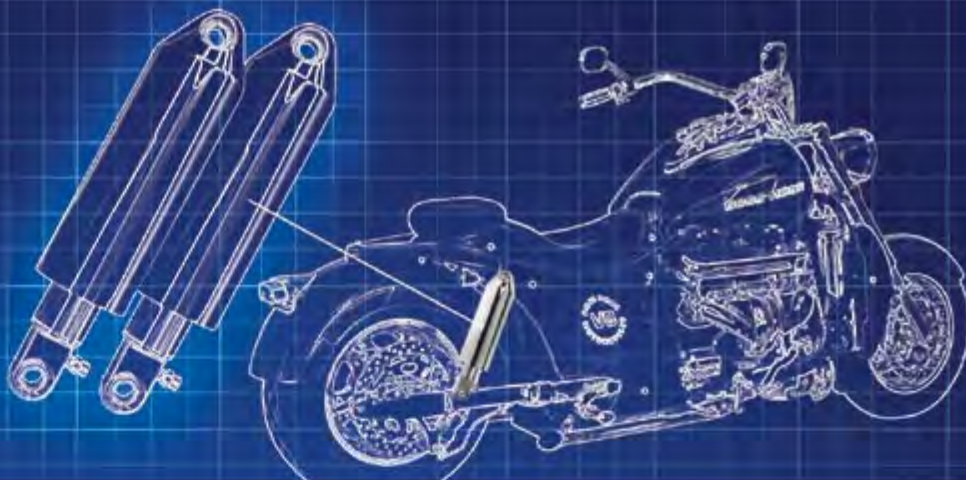

Bleed Feed

PAS-1702-BHC
PAS-1702-BHC-B

NEW

Min. Retracted 11"
Max. Extended 13"
Rear Lift: 2 1/4"
Shock Travel: 2 1/4"
Diameter: 3 1/8"



Kit includes the following: (2) Air cylinders machined from 6061 T-6 billet aluminum, air-control valve, DOT-approved 1/4" line and fittings, air compressor, switch harness, hardware and line cutter.

Simple

PAS-1686-BHC
PAS-1686-BHC-B

NEW

Min. Retracted 11"
Max. Extended 13"
Rear Lift: 2 1/4"
Shock Travel: 2 1/4"
Diameter: 3 1/8"



Kit includes the following: (2) Air cylinders machined from 6061 T-6 billet aluminum, air-control valve, DOT-approved 1/4" line and fittings, air compressor, switch harness, hardware and line cutter.



Available In
High Gloss Black
& Chrome Only!



Bike Photo Courtesy
of California Boss Hoss

AIR RIDE ACCESSORIES

WHEN IT COMES TO AIR RIDE
WE'VE GOT YOU COVERED.



"It's all about the Ride"

97C Air Compressor - Black
PAS-00097-BK



97C Air Compressor
PAS-00097



100C Air Compressor
PAS-10016



100C Air Compressor Kit w/
Hardware PAS-10016-WH



380C Air Compressor Kit w/
Hardware - Available in Chrome
or Black PAS-38033-WH



275C Air Compressor Kit w/
Hardware PAS-27520-WH



Switch Harness
PAS-SV-HARNESS



Switch Harness
PAS-BF-HARNESS



Simple Air Ride Valve for
Lift and Dump only.
PAS-STV



Bleed Feed Control Valve
For All Mono and Side Mount
Applications PAS-BFCV



Bleed Feed Control
Valve For Front & Rear
Applications
PAS-F&R-CV



Softail Bleed Feed Valve
PAS-BFSV



AIR RIDE ACCESSORIES

WHEN IT COMES TO AIR RIDE
WE'VE GOT YOU COVERED.

BLEED FEED TECHNOLOGY
PLATINUM
AIR SUSPENSION

Splash Guards
PAS-0514



Splash Guards
PAS-0515



Splash Guards
PAS-0516



Air Piston 41mm or 49mm
PAS-FTRC



Platinum Air Cylinder
PAS-FTRP



Pressure Gauge
Available in Chrome or Black
PAS-90084 and PAS-90085



1/4" Y Fitting
PAS-Y



1/4" X 1/4" T Fitting
PAS-T



1/4" X 1/8" Swivel Male
T Fitting
PAS-MALE-T



1/4" X 1/8" - 90 degree
Swivel Elbow Fitting
PAS-ELBOW



1/4" X 1/8" - 90 degree
Swivel Female Elbow
Fitting PAS-FEMALE-ELBOW



1/4" X 1/8" Straight Fitting
PAS-STR



AIR RIDE ACCESSORIES

WHEN IT COMES TO AIR RIDE
WE'VE GOT YOU COVERED.



"It's all about the Ride"

Nickle Plate HEX Nipple
1/8 npt
PAS-HEX-NIP



Check Valve
PAS-92823



Rubber Boot and Ring for
Mini Toggles
PAS-RB



Mini Momentary Toggle
Switch
PAS-toggle



Airline Cutter
PAS-CUTTER



DOT 1/4 inch Air Brake Line
PAS-AIRLINE



Circuit Breaker 30 AMPs
Metal
PAS-B30A



Remote Switch
PAS-81283



Platinum Beanie



Platinum Hat



Platinum T-Shirt
Blue



Platinum T-Shirt
Black



PHOTO GALLERY

BLEED FEED TECHNOLOGY
PLATINUM
AIR SUSPENSION

"It's all about the Ride"





SUPPORT

SOME IMPORTANT POLICIES AND THINGS YOU SHOULD KNOW ABOUT PLATINUM AND ITS BUSINESS.



Platinum's Limited Warranty

Platinum products have a one year limited warranty. This warranty covers all material and manufacture defects. Platinum will not be held responsible for any cost of labor associated with the part in question. Warranty will be VOID if the part was improperly installed.

Returns Policy

In the event that an item needs to be returned within the warranty period, you must contact the original seller (dealer) of the part to obtain an RMA return number (required for all returns). Place the return Authorization Number on a visible place on the box. If the number is not there your order will be refused. Also include a copy of the original invoice and a brief description of why you are returning the product.

Refused Orders

All refused packages are subject to a 25% restocking charge, plus all freight, shipping and C.O.D. fees. No returns on special orders.

Electrical Return Policy

Electrical part returns are accepted for the purpose of warranty consideration only. Parts tested good will be returned F.O.B. to the shipper. Defective parts will be replaced due to manufactured defect. If the parts are installed incorrectly due to pinched wires or improper installation warranty will be voided.

Exchange / Missing items

Incorrect orders, damaged or missing items must be reported within 72 hours of the time product is received.

Lost or Stolen Packages

Platinum cannot be responsible for lost or stolen packages, once a package is scanned and delivered. If you would prefer a signature confirmation, please request one at the time of order placement. NO REFUNDS will be issued by Platinum for packages scanned as delivered to the correct Address.

Back orders

Back orders will be kept open and shipped as soon as possible. If there is any reason to cancel your back order, please notify us ASAP.

Payment Policy

We accept the following credit cards: VISA, MASTER CARD, AMERICAN EXPRESS and DISCOVER. All other orders are shipped certified check.

Refunds

No refund once item is open or installed on bike. If the product is found to be defective, we will repair or replace defective part within the 12 month warranty period. All special order sales are final, plus no freight charges will be reimbursed.

DEALER & ORDERING INFO / INDEX



"It's all about the Ride"

Become A Dealer For Platinum

We are always looking to expand our dealer network and to become a dealer of Platinum Air Suspension, all you have to do is fill out the application on our website and then send it to mike@platinumairsuspension.com.

Just know we must receive all of the following items from your company to qualify for dealer pricing. If any of the items are missing, your application won't be processed. So please make sure everything is there before faxing this back or mailing it in so you don't waste our time or your time!

1. A completed Dealer Application Form
2. A copy of business license / resale license
3. Your resale tax number
4. California dealers must fill out a resale tax form or they will be charged sales tax until the form is received.
5. A picture of your place of business or a copy of your company's yellow page ad
6. A copy of your letterhead or business card
7. A completed Credit Card Authorization Form
8. For questions, please do not hesitate to call (714) 871-2424 or email mike@platinumairsuspension.com

Placing Orders

We are open Monday through Friday
8am - 5pm (Pacific Time).

You can place your orders by phone:

Office (714) 871-2424

Fax (714) 871-2427

Product design and specifications are subject to change without notice. For complete up-to-date product information please contact Platinum directly at (714) 871-2424 or visit our website at www.platinumairsuspension.com

Index

About	1	Suzuki M109.	22
Bleed Feed Explained	2	Suzuki GSX-R	23, 24
New Product & Options	3, 4	Kawasaki ZX-10 & 14	25
HD FL Products.	5, 6	Yamaha V-Star	26
HD FL Front & Rear Air Ride	7, 8	Yamaha R1 & R6	27, 28
HD Twin Cam / Softail	9	Yamaha Stryker	29
HD EVO / Softail	10	Honda Fury, Sabre, Shadow & Stateline	30
HD V-ROD	11	Honda CBR	31, 32
HD Sportster / Dyna	12	Can-Am Spyder	33, 34
Indian 2014 to Current.	13, 14	Boss Hoss	35
Indian 2003	15	Accessories	36, 37, & 38
Indian 1999 to 2002	16	Gallery.	39, 40
Victory	17, 18	Support & Dealer Information	41, 42
Ball Mill Cut Option	19, 20		
Suzuki Hayabusa	21		

*Specializing in Air Suspension
for the Motorcycle Industry*

BLEED FEED TECHNOLOGY
PLATINUM
AIR SUSPENSION

"It's all about the Ride"

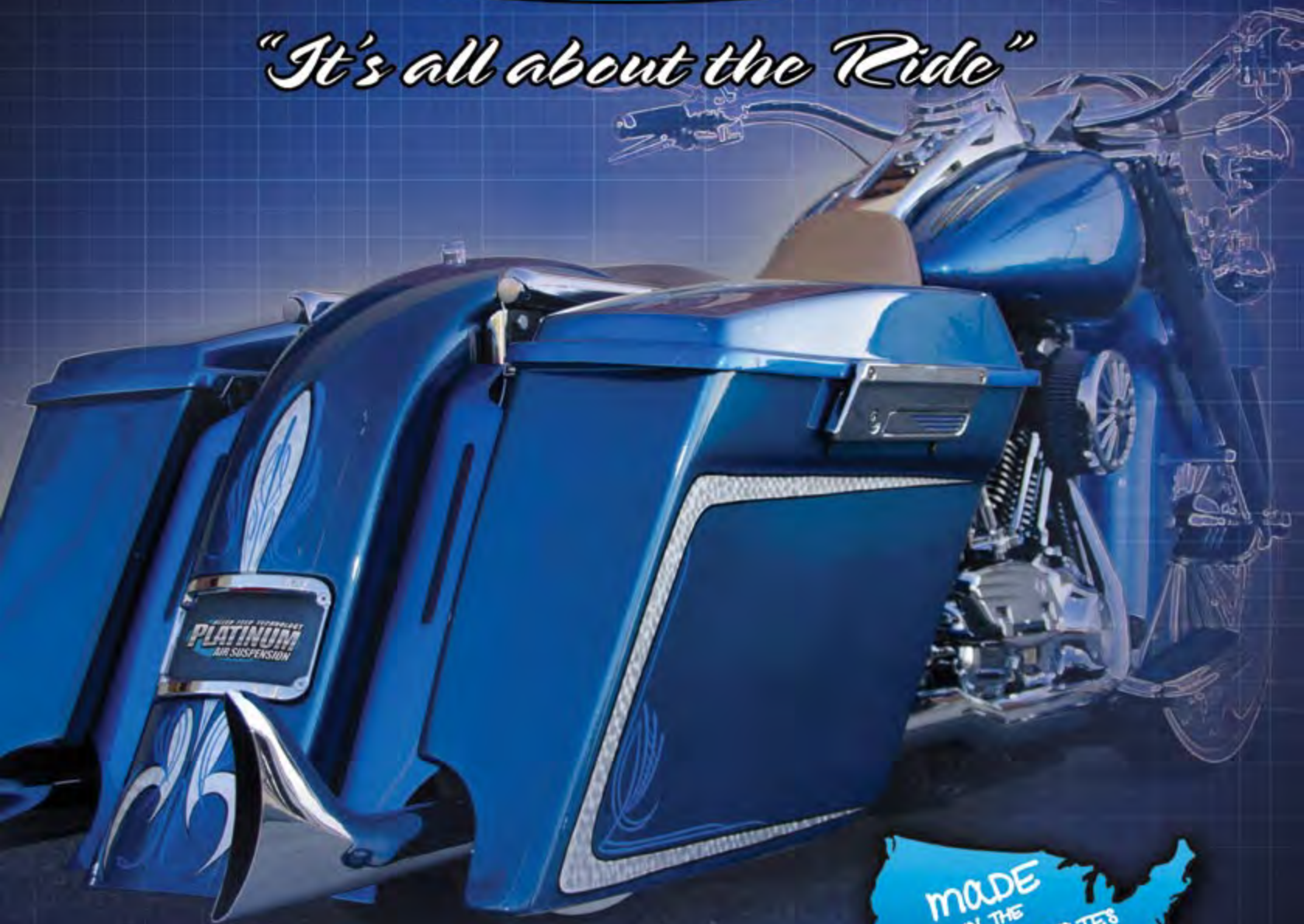

Like us  Follow us  watch us 

www.platinumairsuspension.com | 714-871-2424